

**SIMPLY THE BEST...
SAFER, FASTER, OUTWORKS THE REST**

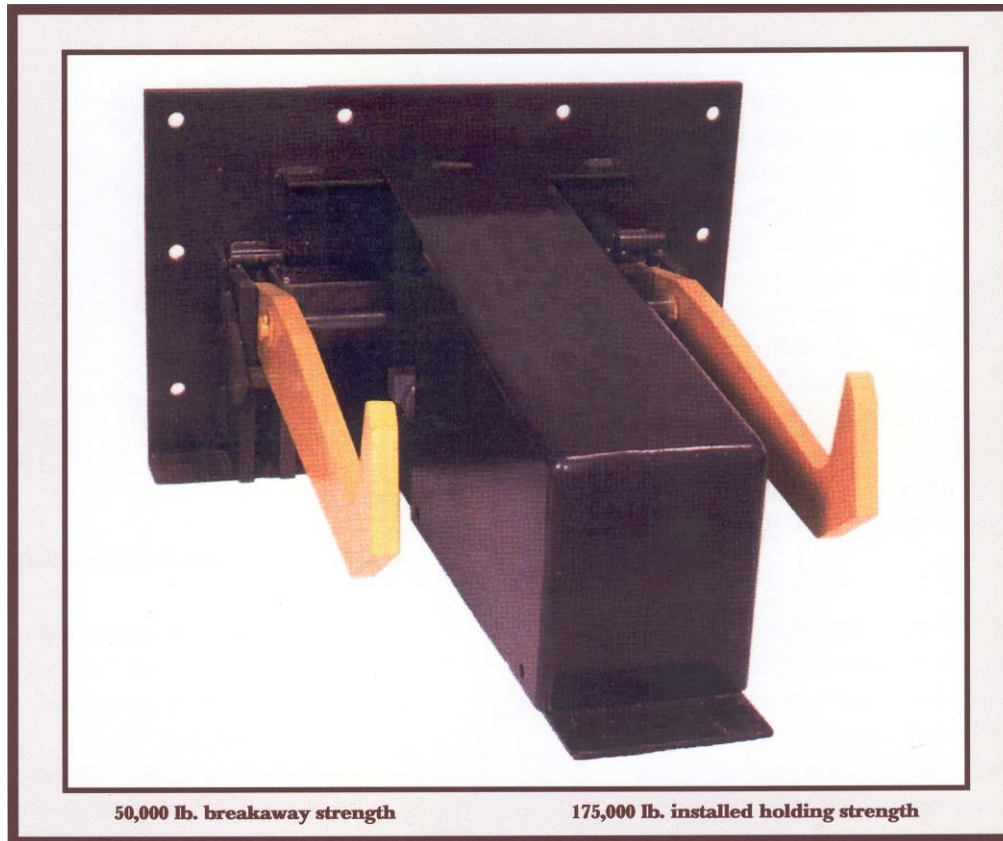

IMPROVE LOADING DOCK SAFETY WITH THE INDUSTRY'S STRONGEST TRUCK RESTRAINT

- Dual arms contact strongest area of ICC bar.
- Low profile design allows dock access for all types of trucks, even UPS and other delivery vans, pickups, etc.
- Compatible with all dock equipment.
- No regular maintenance required.
- Non-impact design avoids damage to truck and restraint during docking maneuvers.
- Captures the widest range of ICC bars.
- Automatic push-button control.
- Full inside/outside communication systems.
- Easy installation, factory tested, no assembly required.
- Helps prevent trailer tip-over.
- Standard 115 VAC power source.

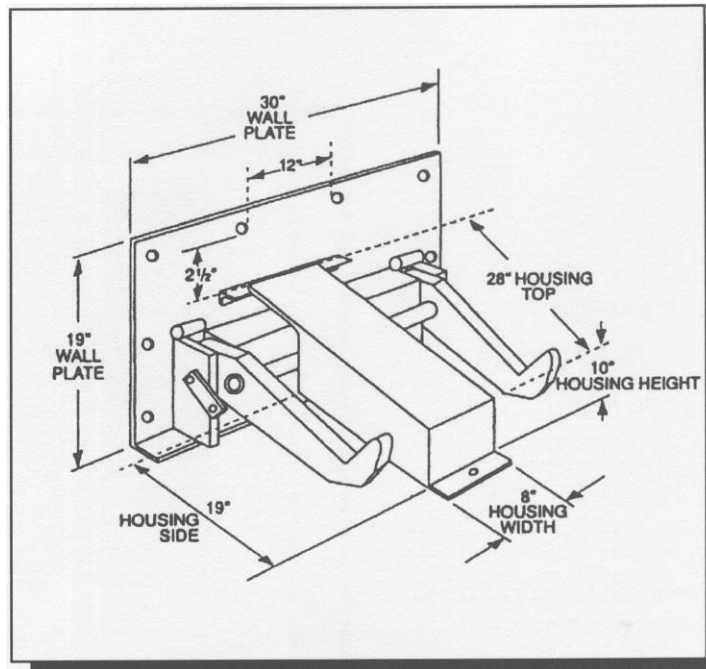

Overview:

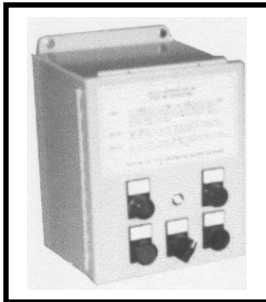

The Atlantic ATR-700 Truck Restraint offers added safety against unexpected truck movement with a 50,000 lb. holding strength. Twin restraint arms engage the ICC bar near the reinforcements, not the usually unsupported center. Reliable operation is provided by push-button control. Restraint arms are extended and retracted effortlessly by the dock attendant at the touch of a button. Arms are held firmly in position against ICC frame. Operating system is self-contained and protected from both physical and electrical overload. The ATR-700 Truck Restraint works without scheduled adjustments, lubrication or risky manual effort by the operator. Operating system is completely enclosed within heavy-duty steel housing for protection from dock debris, the elements and accidental damage.

ATR-700 light communication systems include inside and outside traffic signal controls. The exclusive design allows Restraint arms to freely float with vertical truck movement during loading operations yet maintain positive contact with the ICC bar. The Restraint housing height and mounted location do not restrict access to the dock by smaller vehicles such as UPS trucks, delivery vans or pickup trucks.

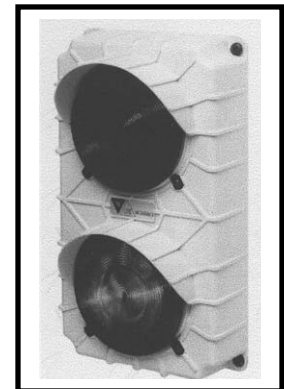

SPECIFICATIONS: Model ATR-700

General Description: The Model ATR-700 Vehicle Restraint, as manufactured by Atlantic Engineered Products, L.L.C., provides automatic positioning of twin Restraint arms via push-button control. Extended arms are held firmly in position by positive torsion spring power. The low-profile, non-impact design allows dock access to all types of trucks and vans. Interior and exterior communication system advises dock personnel of safe/unsafe loading conditions. Unit offers 50,000 lbs. breakaway force and is compatible with all types of dock equipment.

Operation: Automatic system positions the locking arms via push-button control. Design allows restraint arms to float freely with vertical truck movement, yet maintain positive contact with truck ICC bar. Dock attendant presses the "Lock" push-button to engage the truck ICC bar. Arms will extend and exterior traffic signal will change to red. Once engaged the motor will stop and the interior visual display will change to green to advise a good loading condition. If the ICC bar is detected to be excessively weak, damaged or missing, other measures should be taken to secure the truck. The "Unlock" push-button is pressed to disengage the arms and return to stored position. Exterior light will change to green and the interior display will change to amber.

Construction: The operating system housing is constructed of 1/4" and 3/8" thick structural steel weldment. Twin restraint arms are constructed of 1" thick, one-piece flame cut steel plate, each. Restraint shall not acquire impact from truck during docking maneuvers. Unit is designed to attach both to dock wall and ground surface for maximum mounted strength. Restraint offers 50,000 lb. breakaway force and 175,000 lb. installed holding strength.

Electrical: The self-contained gear motor actuator manages positioning of restraining arms with push-button control. Pre-wired operator station is housed in a gasketed enclosure, which meets NEMA requirements for internal or external use. Red and green internal traffic signals are integral with unit operation and advise "Stop", or "Load" conditions. External traffic light provides "Stop" or "Go" signals for truck traffic. Totally enclosed motor is rated at 115V, single phase. Wiring from push-button station to unit junction box, by others.

Safety Consideration:

- Communication System
 - Exterior Red/Green Traffic Light
 - Interior Red/ Green Light Signal
 - Caution Sign
- 50,000 lb. Breakaway Force
- Non-impact Design
- Automatic Push-button Control
- Arms Contact Most ICC Bars
- Mounting Anchors Placed in Shear, Not in Tension
- Pre-tested, Factory Adjusted

Warranty: Coverage provided for one (1) full year from date of installation. Atlantic Engineered Products, L.L.C. will exchange or repair any structural component if found to be defective in manufacture.

Atlantic Engineered Products, L.L.C. reserves the right to alter details without prior notice or incurring obligation.

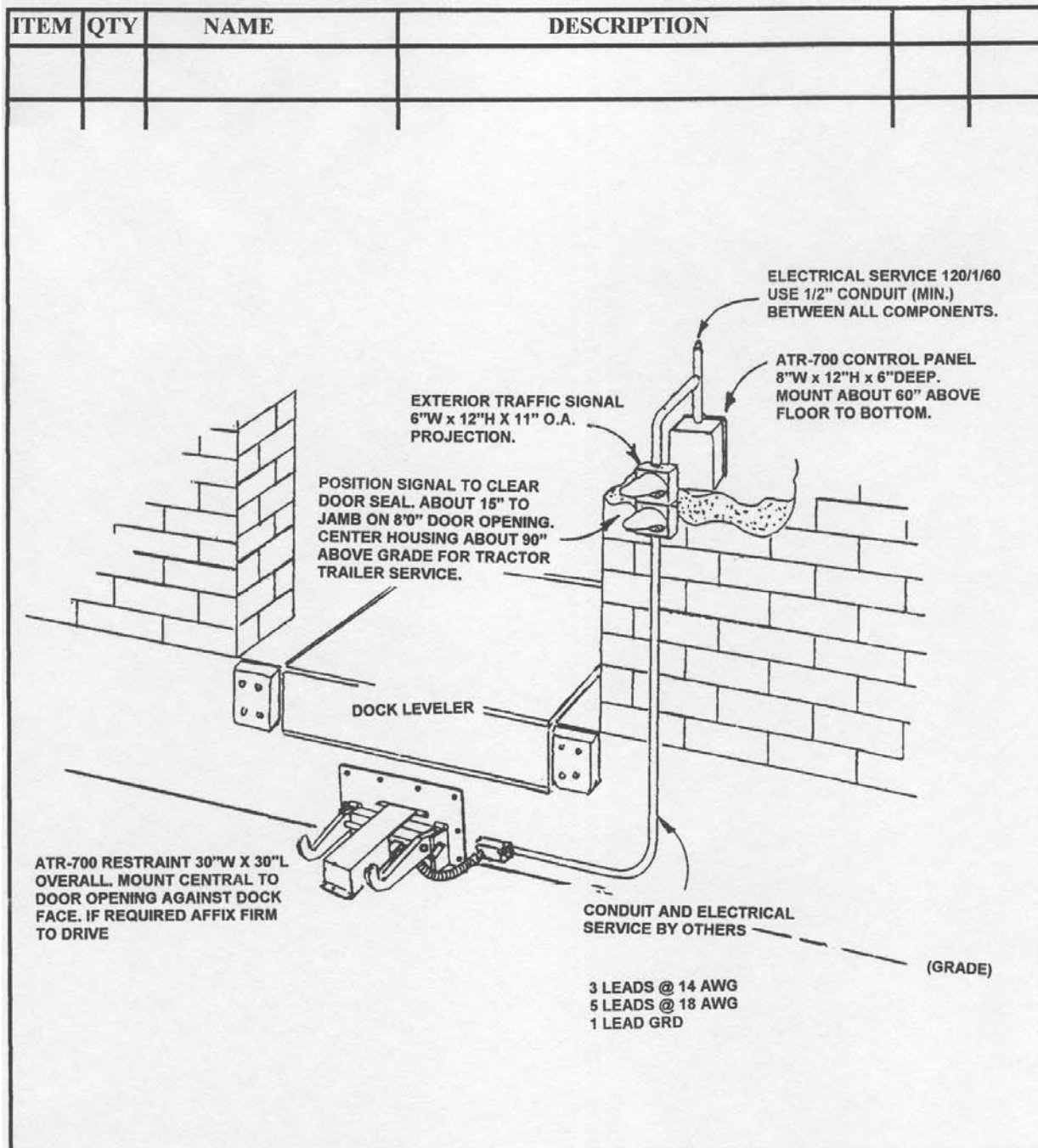

ATLANTIC Engineered
Products, L.L.C.

GENERAL DOCK ARRANGEMENT
ATR-700 TRUCK RESTRAINT

DRAWN BY	DATE	CHECKED BY	SCALE
----------	------	------------	-------

TOLERANCES UNLESS SPECIFIED
MACHINED PARTS + 1/64" 3 DECIMAL PLACES +0.005

DRAWING
NO IMPR

700-001-2